



Aritco 4000 Home Lift



Aritco 4000 - our most compact home lift

The lift has been designed to meet all requirements for comfort, space and design. The lift is available in different sizes, with an option to personalise it with details such as glass walls, a range of varied colours and different materials.

Several advantages offered by Aritco 4000:

- Design, sizes and options created for a home environment
- Minimum interventions in the house
- 95% recyclable materials
- 'A' rated energy consumption according to VDI4707
- Patented screw/nut technology (no oil that can leak)
- The lowest maintenance and operating costs on the market

**ARITCO™**

Aritco 4000

Home Lift

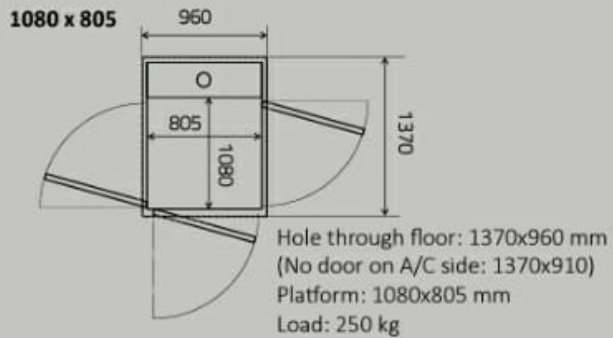
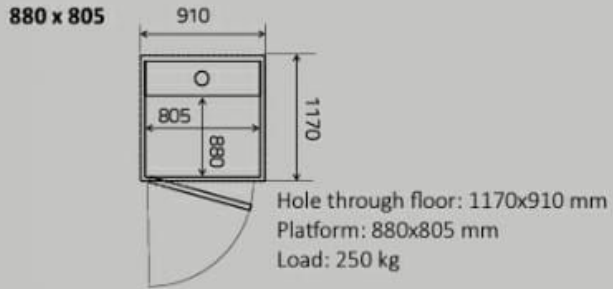
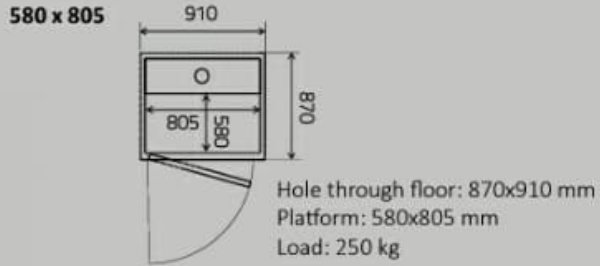
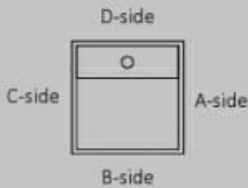

Dimensions

Platform width580-1080 mm	Hole through floor width870-1370 mm	Height of door opening .. 1800, 1900, 2000 mm
Platform length 805 mm	Hole through floor length 910-960 mm	Width of door opening800, 900 mm
Travel height 250-13000 mm	Top height 2300 mm	

Specifications

Drive system: Patented screw/nut system

Rated speed: max 0.15m/s

Platform control: "Hold to run", the button has to be kept pressed during the ride

Landing control: One-touch call

Technical compliance:

European Machinery Directive 2006/42/EC
European standard EN 81-41

Rated load: 250 kg / 2 persons

Number of stops: max 6

Number of doors: max 2 doors per floor

Pit: 50 mm (no pit is required when there is a threshold)

Environment: Indoors

Power supply: 1-phase 230V 50Hz/6.6A/16A slow

Emergency lowering: Battery-powered

Control voltage: 24V

Motor: 1.5kW

For more information, please, refer to our product catalogue or visit our website.

Due to the continuous product development at the company, the information may change without prior notice.